

CULTURA PRESENTS



ACADIA



welcome to our world

Our mission is to create places where people love to work. We do so by cultivating discussions around our clients' culture that informs our design process and approach to solutions, **giving culture a place**. We are an engaged team of diverse expertise and backgrounds, that when combined, provides a **full range of furniture-based services**. We are a living example of what we set out to do everyday; we all love where we work.

who we are



We've built an *inclusive culture*. We are a family. We are *unique* in our industry because *we think differently*. We love where we work and *we do work we love*. The people we hire seek us out. *Our energy is infectious* and our clients love us. Our business is built on *referrals only*.

quick facts



CULTURA WAS BORN +
RAISED IN SAN DIEGO



WOMEN'S BUSINESS ENTERPRISE
NATIONAL COUNCIL **AND**
WOMAN OWNED SMALL BUSINESS

5TH LARGEST
WOSB IN
SAN DIEGO



2018
BEST PLACES TO
WORK WINNER



OVER **500+** PARTNERS
& MANUFACTURERS



900+ CUSTOMERS
NATIONWIDE

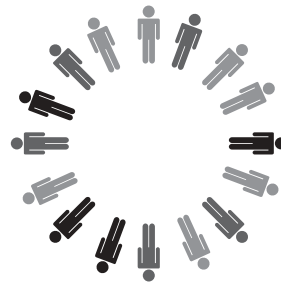

SINCE OPENING
OUR DOORS 10 YRS
AGO WE HAVE
CREATED **45,000**
PLACES WHERE
PEOPLE LOVE
TO WORK



BEST
IN CLASS

2019
HAWORTH
DEALER

HAWORTH BEST IN CLASS DEALER
FIVE TIME RECIPIENT



about cultura

Our Company

We deliver furniture design solutions tailored to our clients and their unique projects. From moves, adds and changes, to procuring new furniture, to managing and warehousing our clients' existing furniture inventory, our team provides a comprehensive array of furniture-based facility services.

Our History

Cultura was established January 1, 2017, to support a progressive style of service our staff and clients helped to envision. Born and raised in San Diego, we've partnered with 900 companies to build spaces together that support their businesses, people and ultimately culture, since 2009.

Our Ideal Client

The client we love to work with is ready for change, trusts we'll deliver, treats us like a partner, values our knowledge and challenges us to think.

Our Love Where You Work® Process

At Cultura, every relationship starts with discovery. We ask the right questions to understand our clients' diverse cultures to gain insight into the opportunities and challenges they face. Then we dig deep to unearth the right solutions. We don't settle for off-the-shelf; our recommendations are highly customized. We help our clients decide which solutions make sense for their business and then we make sure those decisions get quickly translated into action to deliver successful projects.

Financial Statement

We are a very financially healthy company and have reviewed financials for 2018. We would be happy to share our financials with a signed NDA, if needed please reach out to VP of Finance, Jennifer Gisel, jgisel@culturasd.com

Our Partners

We're partnered with Haworth providing their global offering of contract furnishings, including movable walls, systems furniture, seating, storage and wood casegoods to our clients. In addition to Haworth, we represent over 500 manufacturers who provide additional furniture offerings to address our clients' needs.

Our Product and Service Offerings

- New Furniture/Used Furniture
- Refurbished Furniture
- Design Services
- Space Planning
- Workplace Research & Strategy
- Change Management
- Ergonomic Evaluations
- Project Management
- Relocation Services
- Installation Services
- Facility Management
- Warehousing
- Refurbishment Services
- Technical Services
- Inventory & Asset Management
- Customized Purchasing Programs

Our Team

Our 32 people make us different – committed to supporting and challenging our clients in equal measure. We're passionate about making a measurable impact in all we do. Our unique culture and approach deliver enduring results, true to each client's specific situation. We'll always do the right thing by our clients, our people, and our communities.

agenda

1. Team Cultura
2. Schedule
3. Services
4. Product
5. Idea Starters
6. Mock Up

1 team cultura

bios

project team

(leadership)



Anne Bengé | CEO | 30+ years in the furniture industry

At the helm of our organization, you'll find a dynamic leader that empowers our team to be bold in our creativity, fostering a culture of innovation. She challenges the status quo in search of ingenious solutions always curious of emerging trends in business and how these relate back to our clients. Anne is intrigued by the people and processes that make a company unique and how Cultura can impact these organizations, enabling them to do their best work.

RELEVANT PROJECTS: Perfect Bar, Revlon, Legoland, San Diego Downtown Library, Cubic, Sony, Jack in the Box, San Diego Airport Authority, Northrop Grumman

✉ abenge@wearecultura.com ☎ 760.458.9144



Taylor Gifford | VP | 10+ years in the furniture industry

Always looking forward, you can be sure Taylor is one step ahead in exploring new ideas. She's an expert in assimilating all the details to quickly envision cutting edge and results-driven solutions. Taylor will act as your consultant, facilitating the discussions and developing the strategies that will drive an imaginative thought process and move your project forward. A natural motivator, she activates the project team to produce and deliver.

RELEVANT PROJECTS: Metacrin, Psyonix, The Irvine Company, Navigate BioPharms, a Novartis Company, Aira, Canale Communication, Fate Therapeutics, Invivoscribe, Astellas Research Institute of America

✉ tgifford@wearecultura.com ☎ 858.350.5031



SueAnn Mitchell | Territory Sales | 25+ years in the furniture industry

SueAnn is the San Diego Territory Sales Manager for Haworth and will act as the Haworth Representative for this project. In this role, she supports the Cultura team to help our clients realize their strategic workplace objectives with innovative, high-quality, well-engineered Haworth product solutions. Her deep knowledge of Haworth product solutions makes her an invaluable resource to clients.

RELEVANT PROJECTS: Palomar College, San Diego Community College, Cal State University San Marcos, Biocom HQ, Encore Capital, HD Supply, Jack in the Box, San Diego Community College District, Sony

✉ sueann.mitchell@haworth.com ☎ 760.497.4875

bios project team

(the "a" team)



Erica Roman | Designer, Creative | 12+ years in the industry

Erica's ability to engage clients in the design process builds the foundation for creating places where culture can thrive. Inspired by the unique attributes that each project presents, she thoughtfully organizes ideas and concepts that connect people to place. Erica is the creative visionary for our project team. Integrating aesthetics and image, experience and sentiment, functionality and connectivity; Erica will develop the overall design concepts that inform the products and finishes we select.

RELEVANT PROJECTS: UCSD, Center for Creative Leadership, La Jolla Pharmaceuticals, EvoNexus, Psyonix, Jack in the Box, Center for Novel Therapeutics, Dr. Seuss, Cowboy Star, Red Door Interactive, CBRE

✉ eroman@wearecultura.com ☎ 858.350.5015



Kyla Mooney | Designer, Technical | 18+ years in the furniture industry

Never one to see a singular answer, Kyla will broaden the design possibilities that exist on every project with her ability to generate many different solutions. She's an introverted mastermind who meticulously gathers all the information before hitting the drawing board to develop the best ideas for our clients. A designer of detail, she specifies each and every product, down to the nuts and bolts, that goes in the final design package for your project.

RELEVANT PROJECTS: Cubic, Psyonix, Northrop Grumman, La Jolla Pharmaceuticals, High Moon, Sony Electronics, Seer Interactive, Perfect Bar, Jack in the Box

✉ kmooney@wearecultura.com ☎ 858.350.5002



Angie Romano | Designer, Technical | 8+ years in the furniture industry

Angie's design logic is fundamental to our clients' business. She's an expert of observing patterns and behaviors in the workplace and then designing solutions around them. Her thoughtful and methodical approach to projects builds trust with clients and the project team at large, knowing that she'll consistently deliver. Angie will act as the technical oversight to our design team, taking all the ideas and concepts that come out of our conversations with you and putting them into action.

RELEVANT PROJECTS: Gilead, GPI Companies, ACEA Therapeutics, Glysens, Colliers, Mesa College, Scientist.com, Nash Communities, Omniome, Enterprise Holdings

✉ aromano@wearecultura.com ☎ 858.350.5034

(ongoing support)



Dan Martinez | Project Manager | 28+ years in the furniture industry

Dan is a master of orchestrating the complex and chaotic. He meticulously assembles all the details, organizing the team and deliverables, to create a clear roadmap that keeps everyone on track to achieving deadlines. His dedication and calm disposition, allows clients to trust he's thought of everything and that it's all under control. From site meetings and progress checks, to tracking product delivery status with Client Services, to arranging the install team and phasing the order of magnitude, his role is to have you operational Day 1.

RELEVANT PROJECTS: TriLink, AMN Healthcare, Arcturus, Celgene, Genentech, Rakuten Aspyrian, Biolinq, Arena Pharmaceuticals, ThermoFisher Scientific, Forge Therapeutics

✉ dmartinez@wearecultura.com ☎ 619.565.3699



Evelyn Anaya | Manager of Project Management | 3+ years in the industry

Evelyn understands what it takes to coordinate and deliver a successful project. She enjoys the challenges that occur throughout the life of the project and envisions her role to be that of a client advocate; always finding solutions that support her client's goals and overall desired outcomes.

✉ eanaya@wearecultura.com ☎ 858.350.5021



Barbara Dunlap | Client Services | 35+ years in the furniture industry

Barb's knowledge on anything and everything relating to our business and clients is invaluable; she's like an encyclopedia of information. Combine that with her enthusiasm and intuitive ability to know just what you need and you've got yourself the ultimate team member.

✉ bdunlap@wearecultura.com ☎ 858.350.5008

Evelyn and Barb are your ongoing support. They are with you every step of the way, making sure you get on-boarded correctly, working with our design and project management team to input, order and track every single part and piece that goes into creating your new space and ultimately assuring that all of your needs are met.

life science experience

Cultura focuses on delivering the highest caliber of customer service, client experiences and product delivery. Given our exceptional service and premium talent, referral-business has organically become a centerpiece to our company. Our outstanding reputation and quality of work are just two of the many reasons the businesses and organizations below were directly referred to our company and have become lasting clients.



ACADIA Pharmaceuticals Inc.
Agena Bioscience, Inc.
Amgen
AMN Healthcare
Anabios Corporation
AnaptysBio, Inc.
Applied Proteomics, Inc.
Aries Pharmaceuticals, Inc.
Arytha Biosciences LLC
ASML USA Cymer
Aspyrian Therapeutics, Inc.
Astellas Research Institute of America, LLC
Barney & Barney, LLC
BD Biosciences
BP Biosciences
Biocom
BioLabs San Diego LLC
BioLegend, Inc.
Biomed Realty Trust
CSU, San Marcos
Canale Communications, Inc.
CardioCell, LLC
CB Richard Ellis
Celula, Inc.
Chempetitive Group
Cibus US, LLC.
Clarify Medical
Conatus Pharmaceuticals
Confirm BioSciences
Cosmederm Bioscience, Inc.
Cox Business
Cushman & Wakefield
Cymer, LLC
Cypher Genomics
Dart Neuroscience
Dexcom, Inc.

DPR Construction
Eli Lilly and Company
Elsevier
Epic Sciences
Explora BioLabs
Ferguson Pape Baldwin Architects
FI Oncology, Inc.
Fate Therapeutics
Genea Biocells US, Inc.
Genentech
Genomatica, Inc.
Genoptix Medical Laboratory
Gensler
Glysens Incorporated
Greenwich Biosciences a GW Pharmaceuticals PLC Co.
HCP Life Science Estates
HD Biosciences Inc.
Helix Opco, LLC
HG Fenton Company
Ignyta, Inc.
Innovative Lease Services
Janssen Research & Development
Jones Day
Kilroy Realty Corp.
La Jolla Biologics, Inc.
La Jolla Pharmaceutical Co.
Lexent Bio
Ligand Pharmaceuticals Inc.
Mast Therapeutics, Inc.
MEI Pharma, Inc.
Metacrine, Inc.
MicroConstants, Inc.
Neurocrine Biosciences
NuVasive

Orexigen Therapeutics, Inc.
Pacific Building Group
Pacira Pharmaceuticals
Pfenex Inc.
Pfizer
Point Loma Nazarene University
Poseida Therapeutics, Inc.
Prevost Construction
Procopio Cory Hargreaves & Savitch Project Management Advisors
PvP Biologics, Inc.
Qualcomm
Quintiles IMS
RIFT Biotherapeutics
Robinson Brown Design
San Diego Community College District
Sanford Road Associates – Toft Group
Sente, Inc.
Sequenom, Inc.
Shire
Silicon Biosystems
Sirigen, Inc.
Sotera Wireless
STA Pharmaceuticals
Stemmedica Cell Technologies
StemProtein, LLC
Studley
Sydnexis
Takeda Pharmaceuticals U.S.A.
Thermo Fisher
Tracon Pharmaceuticals
Ultimate Labs Inc
Vertex Pharmaceuticals
Wamberg Genomic Advisors, Inc.

relevant projects

BIOLEGEND

8959 Terman Court, San Diego, CA, 92122

Servicing since 2010



BioLegend Phase 1 is the first building of a Master Campus Plan, totaling 8 acres and set to complete in 2019.

The first phase of this 4-building campus is Building 1, an existing structure of 40,000 square feet of office and lab space to support BioLegend's state of the art manufacturing facility. Cultura provided the furniture design, procurement, installation, and project management services for BioLegend Phase 1. Notable features include open office environments, light-filled collaborative spaces, and height adjustable desks. Cultura began working with BioLegend in 2010, and has enjoyed a long lasting partnership through the many stages of their company.

PARTNERS:

Delawie

DPR

Hughes Marino

PROJECT REFERENCE:

Dale Kutsch

✉ dkutsch@biologend.com

☎ 858-455-9588

relevant projects

LA JOLLA PHARMACEUTICAL COMPANY

4550 Towne Centre Ct, San Diego, CA, 92121

Servicing since 2012



Cultura partnered with La Jolla Pharmaceutical Company to expand into their new headquarters in UTC, with 55,000 square feet of creative office space and 25,000 of lab space. La Jolla Pharmaceutical Company brought their previously separated lab operations and business units under one roof to foster collaboration and an inclusive culture. The 3-story building has multiple creative amenity areas including a large breakroom/event space with garage doors opening onto an outdoor patio. The interior design is a celebration of San Diego's environment, with bright and playful furniture throughout the space.

PARTNERS:

McFarlane Architects
Miller Design

Rudolph Sletten
Hughes Marino

PROJECT REFERENCE:

Kate Stemmer

✉ kstemmer@ljpc.com

☎ 858-217-5529

relevant projects

CYMER/ASML

2017 as ASML | San Diego, CA



Cultura has had a long-standing relationship with Cymer that dates back to early 2013. As a continual partner, when Cymer was acquired by ASML Holdings of The Netherlands they turned to Cultura to help design, develop and implement its new company standards.

Cultura provided the project management and labor services to disassemble and remove two building's worth of existing product, while also successfully finding sustainable ways to recycle as much inventory as possible. The approved new standards were implemented and installed across two buildings and 6 floors of office space.

NDA in place for external reference, please contact Cultura directly for information.

2 schedule

schedule







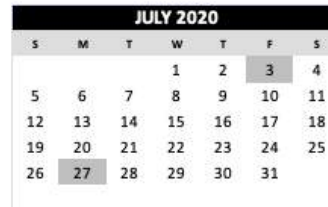
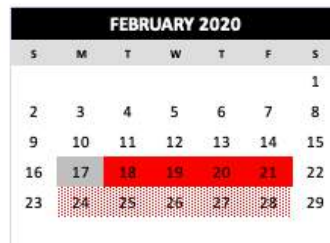
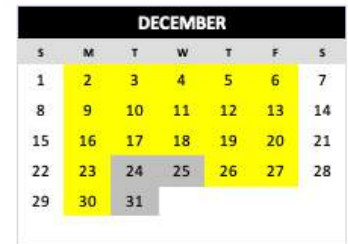
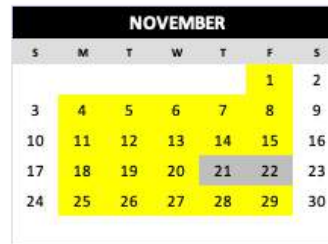







2019/2020

ACADIA



Haworth will hold 2019 list pricing until April 2020

-  **Holiday**
-  **Mock Ups/Vendor Selection**
09.03.19 - 10.31.19
-  **4-8 Weeks Manufacturing**
03.09.20 - 05.01.20
-  **Preliminary Typical Developed**
05.09.19 - 06.28.19
-  **Finalize Design Development**
11.01.19 - 01.31.20
-  **Receiving Product**
05.18.20 - 05.29.20
-  **Furniture RFP**
07.01.19 - 07.31.19
-  **Final Order Sign Off Approval**
02.18.20 - 02.21.20
-  **Installation**
06.08.20 - 06.26.20
-  **Furniture Bid/Evaluation**
08.01.19 - 08.30.19
-  **Order Entry + Acknowledgments**
02.24.20 - 03.06.20
-  **Extra 2 Week Allowance**
(for 10 week leadtime)

Vendor Award Date: October 2019
Est. Move-In Date: July 2020

work plan

design services

- Product Application, Budget and Specifications
- Clarify customer-specific project design requirements for each location
- Assess and make recommendations related to product applications
- Provide alternate options, cost savings suggestions and unique solutions
- Work closely with Design and the Sales Executive during the specification process to ensure proper engineering and specification of product
- Provide typical drawings, specifications and pricing
- Consult with customer's project team and/or Haworth on any questions
- Review typical sizes, footprints for offices and workstations with local design team and/or your facilities team
- Provide summary of National Standards Programs finishes and tailor specifications to each location
- Create and maintain project budget based upon final design selections
- Confirm lead-time impact, if any, based upon final design selections
- Create CAD blocks of Haworth furniture for insertion into the customer's floor plans
- Create CAD installation plans indicating all Haworth furniture
- Inform, coordinate and resolve any furniture-related electrical and data issues with the customer's project team, electrical consultant and site electrician
- Review atypical product applications and make recommendations
- Review quality control issues as required

order services

- Perform final "Triple Check" prior to order entry following client sign-off on final specifications
- Review with the Installation Supervisor all plans and specifications prior to order placement to ensure that orders are correct and safeguard against potential problems
- Enter order into the computer system and proof the computer-generated purchase order. The purchase order will then be electronically transmitted to Haworth with all pertinent notes printed on the purchase order relating to special sizes, finishes, shipping instructions, production deadlines, etc.
- Issue computer-generated acknowledgements of the orders as placed for your inspection and records . A second acknowledgement will be sent providing the shipping schedule
- Examine and proof all acknowledgements against specifications and orders
- Expedite all special items: C.O.M., finishes, special shop drawings of custom items, etc.
- Maintain regular contact with client and Haworth during the manufacturing phase
- Determine most effective shipping rates
- Monitor manufacturing and shipping schedules
- **Order changes can be made up to 21 days prior to the ship date. After 21 days costs will be incurred and installation dates may not be met**
- Ship dates can be adjusted up to 21 days prior to acknowledged ship date without charge
- Provide routine status reports that update Haworth's web-enabled information

The products we have selected fit within the proposed project schedule.

pre-installation

- Inspect site and elevator to assure unloading requirements are met
- Identify staging and placement areas
- Attend Site Meetings for coordination with other parties
- Adjust Work Program according to requirements
- Set Installation Schedule for each area
- Attend project construction for each area
- Finalize installation calendar with general contractor, client and trades
- Pre-installation review and coordination meeting with Project Manager, Field Lead, Designer and Sales
- Executive or Account Manager to check for the last minute changes and review project specifics
- Communicate with computer vendors and/or telecommunications equipment personnel for critical installation staging. A specific pre-installation meeting will be scheduled 2-weeks prior to installation with the cabling vendor and electrician to ensure understanding of cable termination points and final routing of electrical and cabling within the panels

receiving

- Receive product at warehouse, at the job site, or any other prearranged area
- Check all items for damage, file claims as necessary, follow up on all claims, shortages or repairs
- Prepare all furniture for delivery
- Advise designated customer representative of furniture receipt and delivery status

delivery + installation

- Transportation and installation by trained personnel
- Disposal of all cartons and trash. (As needed) day of installation site-walk with customer's project administrator (Facilities Director) and, if required, general contractor project manager
- Coordinate delivery/installation on items arriving after initial installation
- Daily review with Project Manager and Scheduling to adjust manpower requirements
- Designated mid-installation checks to monitor progress and ensure scheduling compliance
- Provide appropriate protection to the customer's premises, including carpeted areas, lift car interiors, all elevator lobby walls, etc.
- Install all Haworth products per the written installation instructions
- Clean products to remove any dust or fingerprints after assembly

testing + commissioning

- Conduct a Walk-Through Inspection with customer upon completion of each phase
- Prepare a punch list of items requiring rectification
- Provide time line for punch list completion items
- Rectify all punch list items for sign-off

post-installation

- Provide information on service and maintenance for furniture including training of personnel when requested
- Assist Accounts Payable personnel with receipt of goods verification and completion of services
- Perform warranty repairs
- Provide technical support to address customer questions and resolve problems at move-in
- Provide product orientation for customer's employees
- Provide training to the customer's in-house maintenance team as requested
- Provide maintenance and reconfiguration services
- Rectify all punch list items to customer's satisfaction
- Welcome to your space! We are there with our #LOVEWHEREYOUWORK packet, product training, ergo evaluations, and donuts/breakfast burritos



3 services

HAWORTH®

Our goal is to work with the best designers and researchers in the world, seeking innovation everyday.



Est. 1948
Holland MI
USA



7000
Employees



160
Countries
95
Showrooms
650
Dealerships



Family Owned
& Operated



\$2B
in Revenue



1st
Zero Waste
to Landfill
Company in
the USA

the process

Our intellectual capital is our people. We dig deep to understand your organization and what makes you tick. We research and hunt through the thousands of options that exist to design and develop ideas that make sense for your business. We refine and sharpen, and then refine and sharpen again until we've got it right. Then we deliver. No two projects are the same, but the measured process we employ is, and that's what yields success.

the how

We take our curated design process to the next level by offering a variety of ways to visually show your space and design concepts, ensuring you know exactly what you're getting. Some of our clients' favorite resources include virtual reality, Bluescape live-interactive technology and virtual fly-through animated videos.

From Haworth's research and studies, to idea boards to different spaces to creating connections with companies that have similar challenges to yours, we connect knowledge and information for our clients.

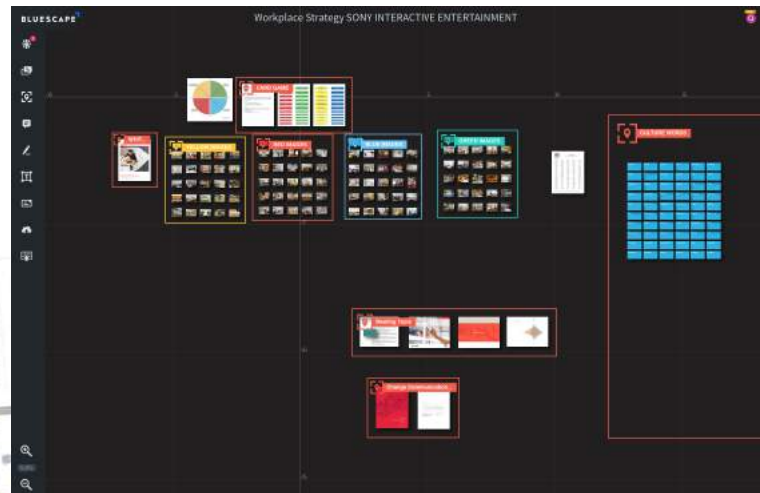

installation

Cultura uses a combination of in-house and outsourced labor. All of the installers we use have been factory trained and certified by Haworth.

Our installation team is led by a lead installer who will work alongside the project manager to coordinate and supervise field resources during the receiving, delivery and installation process. Once your furniture is received, the lead installer will carefully check all items to confirm quantities, correct specifications and inspect for any damages. Once items are qualified, our installation team will mobilize for delivery and installation.

During installation, the lead installer will conduct daily reviews with the project manager to adjust manpower requirements to meet schedule requirements. The installation team will provide appropriate protection to the premises, including carpeted areas, freight elevator interiors and elevator lobby walls, assuring the interior space is in the same condition as pre-installation. The installation team will also dispose of all cartons and trash from the products delivered. Prior to occupancy, the installation team will clean all products to remove dust and fingerprints after final assembly with environmentally friendly products.

EQUIPMENT : Cultura will provide all equipment, supplies, tools, transportation, parking, and trash removal necessary to perform assigned work.

PRODUCT CONDITION : Cultura will insure that all furniture leaving the warehouse is in "clean" condition (dusted, tags removed, ready for use).

PULL LIST CONFIRMATION : Inventory pull requests shall have availability confirmed by fax or electronically (online/email) within 24 hours of receipt of request.

WAREHOUSE : 30,000 sq. ft. located in Chula Vista, CA

POST INSTALLATION SERVICES

Cultura's rigorous procedures keep mistakes to a minimum. Our procedures, from project onset to completion, are in place to keep the punch-list to a minimum, and get the occupants of the project working successfully as soon as possible. Our post installation process includes:

- Provide information on service and maintenance for furniture including
- training of personnel when requested
- Assist accounts payable personnel with receipt of goods verification and completion of services
- Perform warranty repairs
- Provide technical support to address questions and resolved problems at move-in
- Provide product orientation for employees
- Provide training to in-house maintenance team as requested
- Provide maintenance and reconfiguration services
- Rectify all punch lists items to your satisfaction

CONTINUED SERVICE

Cultura's full service team is available to you far after your project completion. You have a direct contact for processing any warranty repairs or maintenance requests if the need arises.

Cultura stands by the quality of our manufacturers with a lifetime warranty. All warranty inquiries will be responded to within 24 hours. Most replacements on warranted items will be completed between 6 to 10 weeks. If the warranted item is a safety issues, we will make every attempt to fix it within 24 hours.

If you have a problem, we make it right.

Your Account Lead and Client Service team assists with any future product re-orders you may need, while our designers keep all historical records of your project archived for fast processing. Providing our customers the ability to communicate with us in a variety of different ways, we work with you anyway, anytime and in any format.

value package

...total value: \$101,800

because we want you to love where you work[®], too.

bonus

+ 82% off primary systems furniture + a 5-year hold on discounting ensuring any future orders are leveraged with the same buying power

+ No deposit required for order placement

Three project designers providing both creative + technical services

based on approx. 500 hours at a rate of \$65/hr

**cost savings
\$32,500**

Analysis for possible existing inventory reuse

based on approx. 50 hours at a rate of \$40/hr

**cost savings
\$2,000**

If you choose to relocate any existing product and partner with Cultura for the move, we will give 35 hours of space planning toward move services at no cost.

**cost savings
\$1,400**

Full Time Project Manager with 20+ years of experience coordinating behind the scenes and onsite logistics with contractors and various outside trades.

based on a rate of \$65/hr

**cost savings
\$50,000**

'Welcome to Your Space' guided tours for employees showing full office amenities, functional design and comes accompanied by a breakfast buffet, hosted by Cultura

**cost savings
\$1,300**

Post-Move onsite ergonomist will provide trainings and individual fittings to ensure employees will know how to adjust their tools for optimal comfort + health.

**cost savings
\$3,400**

Post-move programming strategy assessments to help ensure employees are engaging and utilizing the space as effectively as possible.

If areas are underutilized Cultura will conduct employee feedback forums in conjunction to proposing alternative options for maximizing space efficiencies.

**cost savings
\$4,500**

Cultura will offer Acadia (10) bays of storage for 60 days at no cost.

**cost savings
\$2,500**

Option for mock up model of office furniture allowing users to test out configuration, plan accessories and communicate future plans to employees prior to official move

**cost savings
\$4,200**

biocom contract

BIOCOM EXCLUSIVE SUPPLIER

In 2014, Cultura was selected as the exclusive supplier of contract office furnishings for BIOCUM and its members. This contract was awarded to our team after the successful completion of a 6-month RFP process, vetted by the BIOCUM Purchasing Group and a committee comprised of individuals from BIOCUM member companies.

VALUE TO BIOCUM MEMBERS

Through the collective purchasing resources of BIOCUM and its 800+ members, **BIOCUM members can access deeply discounted products and services from Cultura** to effectively support the successful growth and development of their organizations.

BIOCUM MEMBER BENEFITS INCLUDE:

- Best in class furniture lines
- 80+% discounts on Haworth primary systems furniture
- Huge discounts off other core Haworth product lines and ancillary brand products
- No charge services (planning, design and project management) with the purchase of new furniture
- Discounted labor rates
- Favorable payment terms



future needs

Cultura offers Biocom members a simple and easy process to support future requests.

what you can expect:



Single point of contact for all business needs



Award winning Best in Class service



Guaranteed response to inquiries within 24 hours



Provide training to in-house maintenance team



Post occupancy customer surveys at no additional costs



Cultura provides an additional 5-year warranty above and beyond the manufacturer's warranty



Guaranteed 5-year product discount hold

what we offer:

- Streamlined design process
- Specification/order processing
- Maintain historical achieve of design plans
- Price increases, if any, shall not exceed an aggregate of 5% over a 12-month contract period for Haworth product
- Ergonomic training for employees on product
- Performance guarantee

**#LOVE
WHERE
YOU
WORK** 

4 product

product testing + durability

HAWORTH®

Haworth tests its products to industry and international quality and durability standards. International standards are used depending on the global distribution of the product. Attention to quality begins with our manufacturing facilities, all of which are certified to ISO 9001:2015, ISO 14001, U.L., and A2LA. Our products, developed using Design for the Environment (DfE) principles, are tested to meet or exceed all relevant industry quality standards (ANSI BIFMA, UL/C-UL, ADA, Flammability, USEPA, ETV, ASTM, GREENGUARD). All products are covered by industry-leading warranties.

We take durability to the next level with our internal Engineering Specifications. For example, our ES1285 “Seam Welds on Compose Panel Frame Tubes” gives our product up to seven times the expected life of the product. These specifications typically use ASTM standards during the test phases of design.

Haworth’s Test Lab employs a functional testing perspective that dictates multiple test units must survive a total of seven lives of durability or static loads as required per each relevant test. A complete test cycle (seven lives) must be failure free; if a failure does occur in testing, Haworth’s Product Engineering group must implement a design modification, or the Manufacturing Engineering group must institute a process change, which must then be validated by an additional run of multiple test units to seven lives per test, until the cycle is completed successfully.

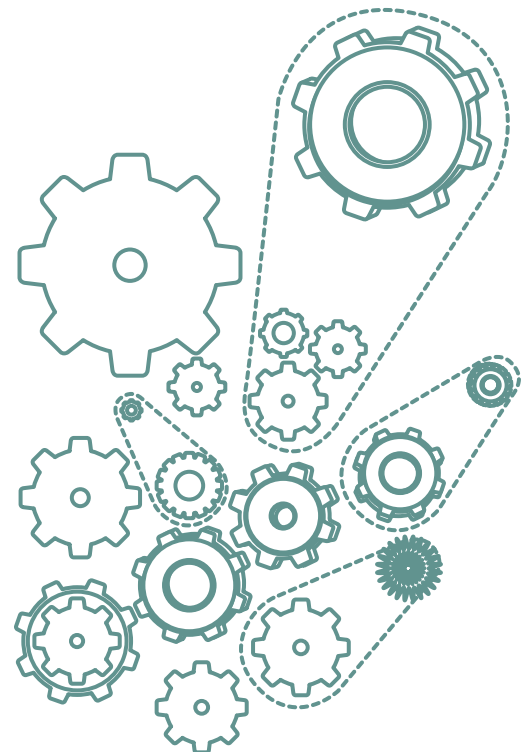

integrated palette HAWORTH®



**great alone.
better together.**

Integrated Palette is a grouping of product lines that work together seamlessly to adapt to changing needs in your work environment - allowing maximum flexibility in configuration, design and connectivity.

unscripted design. endless configurations.

Integrated Palette offers products that respond to changing business needs, saving time and money while providing ease and flexibility during churn and shifting workstyles.

**Learn more about this
complete Kit of Parts**

<https://bit.ly/2IMrqVe>



non-obsolescence

HAWORTH®



Haworth tends not to obsolete products. Instead, we enhance them with the trends of the market in mind, as well as how they fit into our Integrated Palette portfolio. This provides the best long-term value in the industry. Haworth recognizes the difficulties caused by product obsolescence and its impact on customer resources and manufacturing. We strive to improve our products continuously over time to deliver the best in design and engineering. We are strongly committed to providing you with furniture and solutions that will meet your interiors needs, both now and in the years to come.

In the rare event Haworth finds it necessary to discontinue a product, Haworth dealers and customers are notified at least a year in advance of discontinuation. It is standard operating procedure for our field teams to work to find a mutually agreeable solution with our customers.

product brochures

HAWORTH

Planes® | Tables & Benching





Encourage Movement

Give people the choice to sit or stand and change postures throughout the day with Planes height-adjustable tables and benching. Both are available with either manual or electronic mechanisms to bring the worksurface to the desired height. With their clean, simple, crisp aesthetic, Planes fits into almost any environment.



Enhance Learning

Planes training tables work together in dynamic applications to help ensure people stay engaged and connected with learning. Surfaces accommodate meetings and training sessions with technology devices for ad hoc or classroom-style settings. Planes training tables are designed for people to effortlessly move around and easily reconnect to power and data.



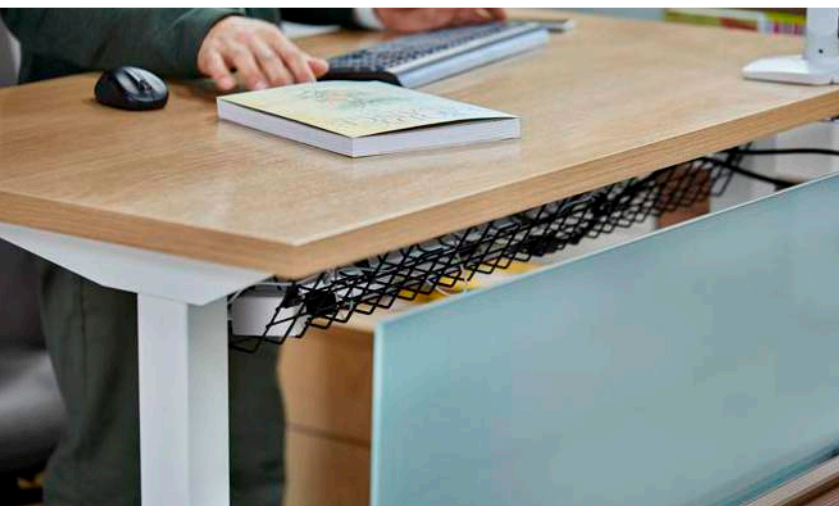

Nurture Interaction

Planes tables allow people to quickly come together in a variety of ways—from formal meetings to spontaneous interaction. Conference tables create a strong statement with smart surface cutouts, power distribution, and wire management. Multiple surface options, varied table heights, and a cohesive aesthetic optimize collaboration in lounge and social settings. Complement interactive activities with carts, credenzas, easels, and information boards that bring design continuity to any space.

Design Choices

With a wide range of choices for tops, bases, edge options, and finishes, Planes tables and benching offer a breadth of application variety and easy specification. Designed as part of Haworth's Integrated Palette™, Planes coordinates with other product lines to create complete environments.



HAWORTH®

Haworth is a registered trademark of Haworth, Inc.
© Haworth, Inc. 2018 03.19
haworth.com | 800.344.2600

Invest in Business Success

As organizations grow and evolve, changing business strategies and employee needs impact space design. Haworth is your trusted partner to help fulfill your client's workplace vision while maximizing their investment.

To learn more, visit haworth.com/planes.

Calibration and Settings for the Planes Height-Adjustable Tables

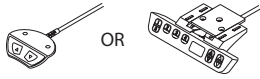

FOR ELECTRIC TABLES

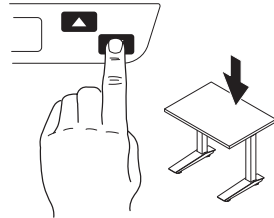

Initial Calibration

After assembly *all* electric tables must be calibrated to insure smooth and trouble free movement.

1. Lower the table to the lowest height by pressing the down arrow on the switch.
2. Continue to press the down arrow for 5 to 10 seconds.

NOTE: The table will readjust itself if needed.

Follow-up calibration

1. Inform the user that the table should be recalibrated once every month by following the instructions above.
2. The table should also be recalibrated if jerky or uneven movement is noted.

PRESET SWITCH INSTRUCTIONS

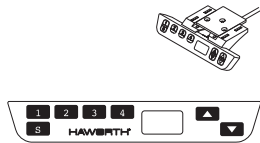

Saving a height position with the preset switch

1. Position the top to the desired height
2. Press the S button
3. Within 5 seconds press the desired number key (1-4) until a double click is heard.

NOTE: The readout will show for example S (number) until the double click is heard and then the height readout will return.

①

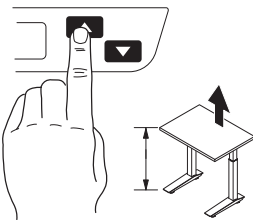

②

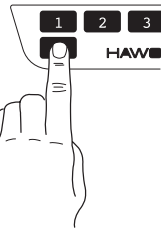

③

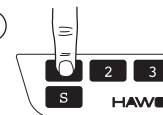

Moving to a preset height

1. Press the appropriate number button.
2. Continue to press the button until the saved position is reached.

Changing from inches to centimeters

The table ships set to read in inch increments but can be changed on site to read in centimeters.

1. Press the 1, 2 and up arrow buttons simultaneously
2. Use the up and down arrow keys until the readout shows S 5
3. Press the S button to complete
4. Use the same procedure to switch back to inches.



With your internet-enabled camera phone, visit get.neoreader.com and download the 2D scanning application to use this barcode.



float[®]



Introducing Float

The World's Most Revolutionary Height-Adjustable Table

Thanks to its innovative and proprietary design, the Float height-adjustable table solves the problems and limitations of current-generation sit/stand tables, gracefully adapting to a vast range of heights and weights with exceptional ease of use and safety features. Its ingenious counterbalance mechanism provides constant counter-weighting force that allows the table to move fluidly between sitting height and standing height, while accommodating the ergonomic needs of 99% of users.



The Dangers of Sedentary Work

While most office workers sit for the majority of their workdays, research shows that all-day sitting is a serious health risk. But standing all day at work isn't healthy either, causing discomfort and swelling in the legs and feet. Therefore, the most effective way to maintain health and comfort in the workplace is to alternate periodically between sitting and standing postures.

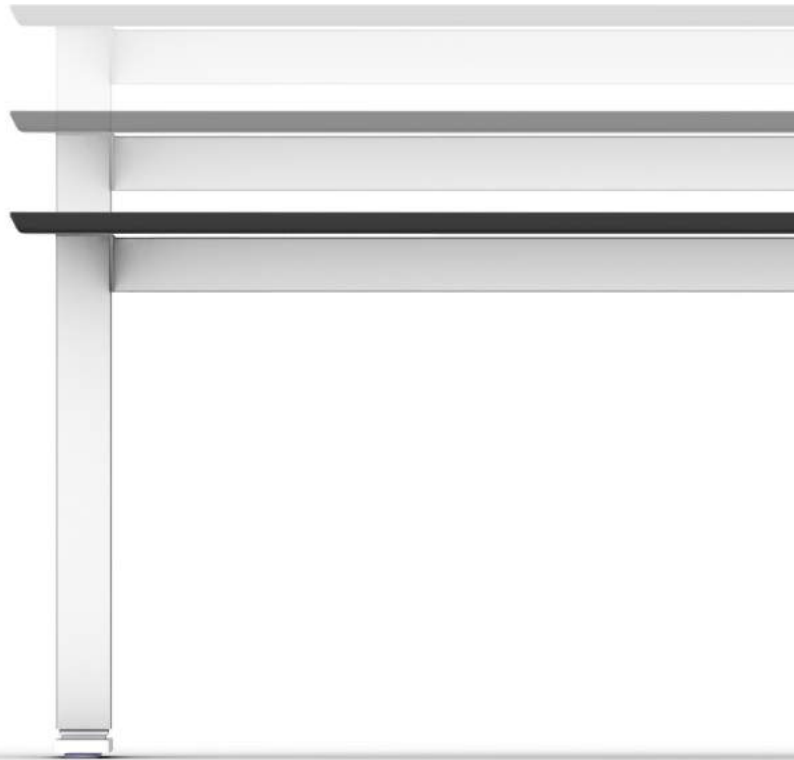

Features

- Unmatched performance and ease of use encourage desk-bound workers to regularly alternate between sitting and standing postures for long-term health
- Simple, single-handed weight adjustment instantly accommodates changes in tabletop weight
- Innovative safety features allows up or down adjustment only when the desktop and contents are properly counterbalanced
- With a clean, sophisticated aesthetic, Float complements any work environment while offering plenty of room under the work surface for legs, knees, and feet
- Built for a long, serviceable life and limited carbon footprint, the Float height-adjustable table is made using minimal parts and manufacturing processes and is comprised predominantly of recyclable steel

Environmental Story

Humanscale supports a materials economy that is healthy and safe for people and the environment. That's why unlike most height-adjustable tables, Float uses premium grade powder coat wood tops that are made without formaldehyde. Certified as one of the world's first Living Products by the International Living Future Institute, when you purchase a Living Product-certified configuration of the Float table, you are making a positive contribution to the environment. Learn more at Humanscale.com/LivingProductChallenge.

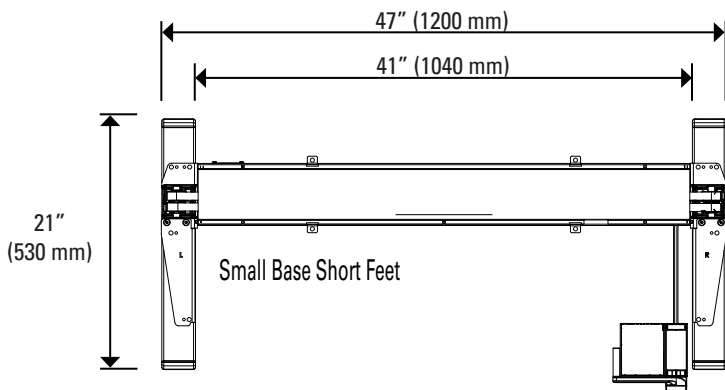
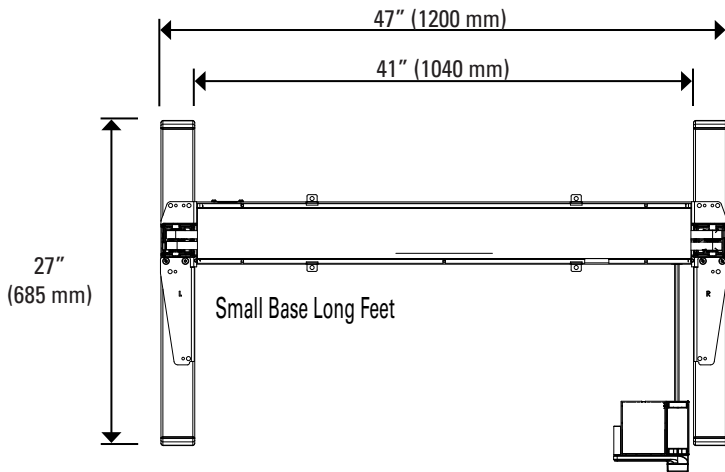
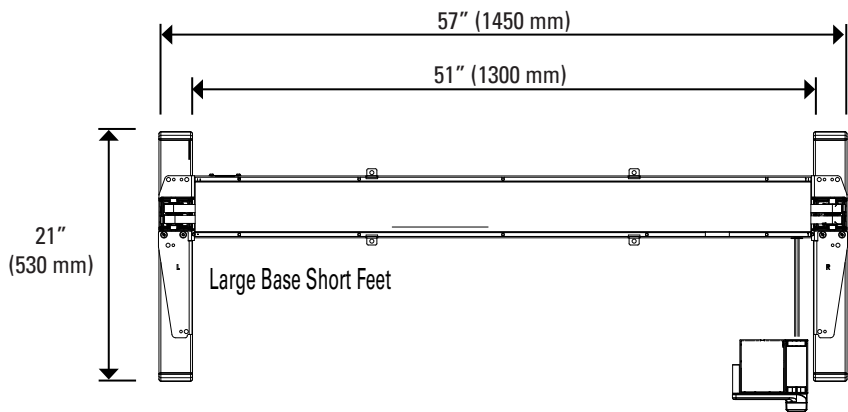
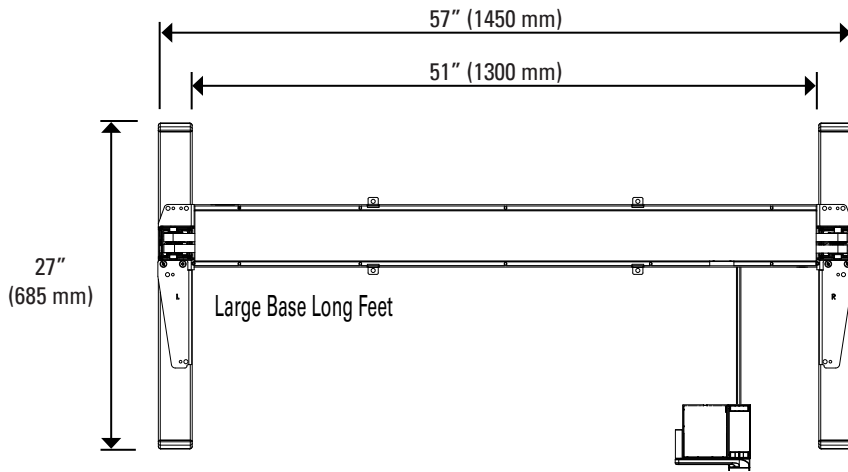

Specifications

- Provides an exceptional 20" of height adjustability (27" to 47" from the floor, excluding tabletop thickness)
- Counterbalances up to 130 lbs. of desktop weight (including the tabletop)
- Accommodates work surface widths from 48" (1200 mm) to 72" (1800 mm) and depths from 24" (600 mm) to 30" (800 mm), including work surfaces from most manufacturers
- Meets BIFMA requirements for load, capacity and stability
- Made from recyclable steel and aluminum
- Includes a 5-year, 24/7 warranty

Colors and Finishes

Black Base

Silver Base

White Base

Black Work Surface

Gray Work Surface

Platinum Work Surface

Tan Work Surface

White Work Surface

2019 RUSH Program Guide

When customers need a quicker solution, Haworth offers the RUSH program.

The RUSH program is designed to provide fast delivery of some popular products, reducing downtime and keeping projects on schedule.

Available for decades, the established RUSH program is currently undergoing a multiphase renewal to improve its lead times and relevance. The pilot phase focuses on a select group of seating, tables, and Ergotron accessories with quicker delivery times. See the new April 2019 RUSH price list for product offering and more details.

Pricing

Haworth dealers can access standard dealer pricing (SDP) for RUSH orders through the following price agreements:

Preferred	Authorized
57591 AA	57778 AA

Additionally, Haworth provides RUSH services and pricing to customers with current contracts when they require expedited orders.

Maximum Order Quantities

Seating	\$75,000 List	50 pieces
Tables	\$35,000 List	15 pieces
Accessories	\$5,000 List	20 pieces

Splitting large orders into smaller orders to get RUSH lead times is not allowed.



Fern®



Zody®



Hop®



Soji®



Very®



Ergotron®



Improv® HE

Ships in 10 business days or less from the date the order is submitted—at no additional charge

Weekends, holidays, and scheduled plant closings are not included as business days.

Haworth NOW

FAST AND AFFORDABLE

» 2-3 DAY DELIVERY*

» REGIONAL PROGRAM

- Alaska
- Arizona
- Alberta
- British Columbia
- California
- Hawaii
- Idaho
- Nevada
- Oregon
- Utah
- Washington

* Shipments to Alaska & Hawaii will have additional transit time.



April 2019 Catalog

Seating



Fern® Value Model

SFT-U0-7S01A5-3A18-MBCL-TRF-TRTF

- 4D Arms
- Seat-Depth Adj.
- Back Stop
- Plastic Base
- Hard Casters
- Tellure-Black Seat
- Coal Mesh
- Black Plastic Trim
- Pitch Aluminum Trim
- Black Base



Zody® Value Model

SZT-20-711MA5-3A18-MA1-TRF-TRF

- 4D Arms
- Seat-Depth Adj.
- Asym. Lumbar Adj.
- Back Stop
- Plastic Base
- Hard Casters
- Tellure-Black Seat
- Support Mesh
- Black Trim
- Black Base

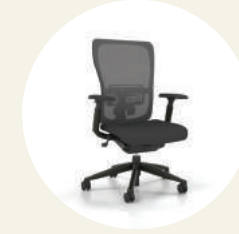

Zody Ergonomic Model

SZT-20-724MA1-3A18-MA1-TRF-TRF

- 4D Arms
- Seat-Depth Adj.
- PAL Back System
- Back Stop
- Forward Tilt
- Aluminum Base
- Hard Casters
- Tellure-Black Seat
- Support Mesh
- Black Trim
- Black Base



Very® Value Model

SCT-20-7115-3A18-MSF-TRF-TRF-TRF

- 4D Arms
- Seat-Depth Adj.
- Asym. Lumbar Adj.
- Back Lock
- Plastic Base
- Hard Casters
- Tellure-Black Seat
- Black Mesh
- Black Plastic Trim
- Black Aluminum Trim
- Black Base



Very Basic Model

SCT-20-411P-3A23-MS7-TR7-TRLE-TR7

- Height-Adj. Arms
- Asym. Lumbar Adj.
- Back Lock
- Plastic Base
- Two-Tone Casters
- Tellure-Jodhpurs Seat
- Fog Mesh
- Fog Plastic Trim
- Metallic Silver Aluminum Trim
- Fog Base



Very Ergonomic Model

SCT-20-7141-3A18-MS7-TR7-TRLE-TRLE

- 4D Arms
- Seat-Depth Adj.
- Asym. Lumbar Adj.
- Back Lock
- Forward Tilt
- Aluminum Base
- Hard Casters
- Tellure-Black Seat
- Fog Mesh
- Fog Plastic Trim
- Metallic Silver Aluminum Trim
- Fog Base



Soji® Basic Model

SJT-20-411A5A-3A18-XT1-TRF-TRF

- Height-Adj. Arms
- Seat-Depth Adj.
- Lumbar Adj.
- Back Lock
- Plastic Base
- Hard Casters
- Tellure-Black Seat
- Carbon Mesh
- Black Trim
- Black Base



Soji Ergonomic Model - Black

SJT-20-711A5A-3A18-XT1-TRF-TRF

- 4D Arms
- Seat-Depth Adj.
- Lumbar Adj.
- Back Lock
- Plastic Base
- Hard Casters
- Tellure-Black Seat
- Carbon Mesh
- Black Trim
- Black Base



Soji Ergonomic Model - Fog

SJT-20-711A7A-3A23-XT9-TR7-TR7

- 4D Arms
- Seat-Depth Adj.
- Lumbar Adj.
- Back Lock
- Plastic Base
- Two-Tone Casters
- Tellure-Jodhpurs Seat
- Steel Mesh
- Fog Trim
- Fog Base

HAWORTH®

Tables



Hop®

TVBA-2TVC-TRPLS

- Hop Base
- Dual-Stage
- Non-Programmable
- 2-leg
- T-leg Base
- 29"D
- Smooth Plaster



Hop

TVBA-2TVC-TRMC

- Hop Base
- Dual-Stage
- Non-Programmable
- 2-leg
- T-leg Base
- 29"D
- Metallic Champagne



Hop

TVRA-2958-LJSNTV-HWL-HPWL-TRPLS

- Rectangular Table
- Dual-Stage
- Non-Programmable
- 29"D x 58"W
- Linen Laminate
- Linen Edgeband
- Smooth Plaster T-leg Base



Hop

TVRA-2970-LJSNTV-HWL-HPWL-TRPLS

- Rectangular Table
- Dual-Stage
- Non-Programmable
- 29"D x 70"W
- Linen Laminate
- Linen Edgeband
- Smooth Plaster T-leg Base



Hop

TVRA-2958-LJSNTV-HWL-HPWL-TRMC

- Rectangular Table
- Dual-Stage
- Non-Programmable
- 29"D x 58"W
- Linen Laminate
- Linen Edgeband
- Metallic Champagne T-leg Base



Hop

TVRA-2970-LJSNTV-HWL-HPWL-TRMC

- Rectangular Table
- Dual-Stage
- Non-Programmable
- 29"D x 70"W
- Linen Laminate
- Linen Edgeband
- Metallic Champagne T-leg Base

Haworth reserves the right to cancel or modify this promotional program at any time without the prior consent or knowledge of any involved parties. Standard Haworth terms and conditions apply. Please reference Haworth Seating and Tables price lists for details. Haworth and Haworth Dealer Confidential. ©Haworth Inc. 2019 04.19

Belong™

Accessories

PRODUCT INFORMATION SHEET



HAWORTH®



Belong Accessories
Best of NeoCon
Silver 2012

Designed to Give Back to the Individual

Introducing Belong Accessories, including Work Tools, Screens and Power Access, created by the Haworth Design Studio. Belong Accessories are designed to give back to the individual through personal and customizable tools. The Belong line provides for personal work needs while supporting the ongoing changes individual workers regularly face.



Embrace Change Through Choice

Belong Accessories offer an array of products to support a broad range of needs. Choose clean and simple work tools, such as paper trays, tool cups and blotters, or privacy screens of various heights, monitor arms, and worksurface-height power taps. Users have choices to support their changing needs.

As part of the Haworth Integrated Palette™, Belong Accessories can be used with the Compose® System, Patterns™ Architectural System, Planes® Conferencing Solutions, or within Enclose® Moveable Walls. Consider hanging select Belong Work Tools from the Beside® Storage slotted stanchion, or mount them to the tool rail on a Reside® desk.

Provide Future Assurance

Only Haworth can offer a truly integrated kit of parts, created to support the widest range of environments and offer future assurance to clients who recognize their investment must be effective for years to come. With the addition of Belong Accessories, the kit of parts gets even stronger.

Belong Work Tools

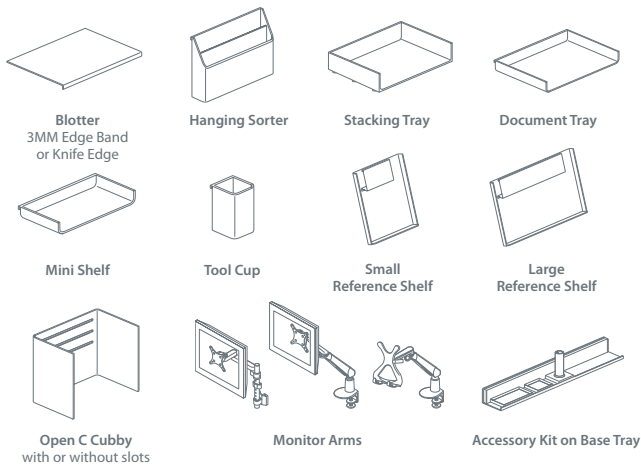

Belong Screens

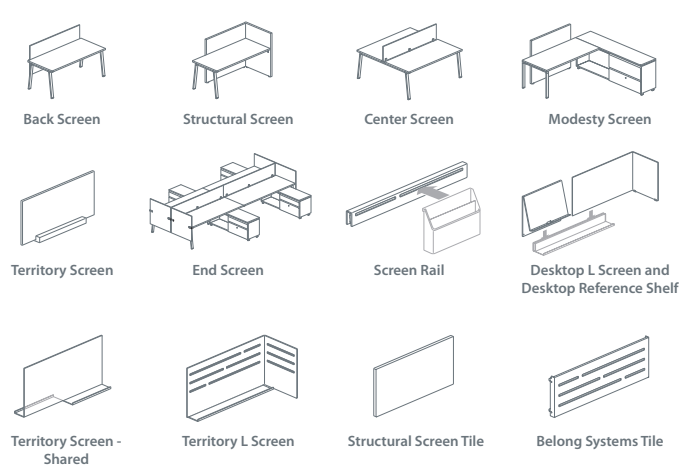

Belong Power Access



Active Components™





Inviting, Personal, Resourceful Spaces

With real estate at a premium, organizations are being tasked to find new ways to maximize space with smart, multi-use, and agile products that improve efficiency while supporting employee engagement and the diverse ways people work.

Active Components offers solutions that help make people and space more adaptable and effective, with light, appropriately scaled pieces designed especially for compact footprints. Clever vertical storage options and suspended elements make use of underutilized space and free up working area to create inviting, comfortable workspaces with flexible elements that support both collaboration and focus work.



Deconstructed Design

Active Components was inspired by deconstructivist architecture, which is characterized by manipulating a structure's surface or shape. Similarly, Active Components defies visual logic. A variety of pieces come together on multiple planes to take advantage of underutilized space with parallel, perpendicular, or cantilevered planning approaches.

Draw People In

The variety of shapes, configurations, textures, and mix of materials create comfortable, cozy workspaces that evoke a residential atmosphere. Active Components freshens up a space with warm elements that support changing postures, memory cues, collaboration, and focus work—creating inviting spaces that draw people in and foster engagement.

Make Every Inch Count

Designed specifically to fit into smaller workstations, Active Components maximizes space while supporting worker performance. Suspended pieces provide smart, multi-use storage while accessories and floating shelves create vertical storage to optimize the footprint.



Offer Variety and Choice

Active Components helps make open-plan spaces perform better for people working individually or in groups through elements that range from accessories to furniture. Open and light in scale, it brings a sense of improvisation and energy to the workspace, enabling personalization and adaptability to suit people's needs.

Design Choices

The expressive qualities of Active Components provide more options to create inviting spaces that convey unique characteristics of corporate and individual brand. A wide range of colors, fabrics, and material types create a residential look, adding color, texture, and warmth to the space. Part of Haworth's Integrated Palette™, Active Components integrates with several popular product solutions. Current Haworth customers can easily add Active Components to an existing workspace to enhance culture and brand.



HAWORTH®

For more information call 800.344.2600 or 616.393.3000.
Download additional copies at haworth.com

This brochure is printed on FSC® certified U2:XG™ paper, manufactured with electricity in the form of renewable energy (wind, hydro, biogas) and contains a minimum of 30% post-consumer recovered fiber. FSC is a global benchmark for responsible forest management.



Haworth is a registered trademark of Haworth, Inc.
Printed in USA ©Haworth, Inc 2017 8.17 Item #0251
haworth.com | eu.haworth.com | ap.haworth.com



5 idea starters

workstations

6x6 concepts

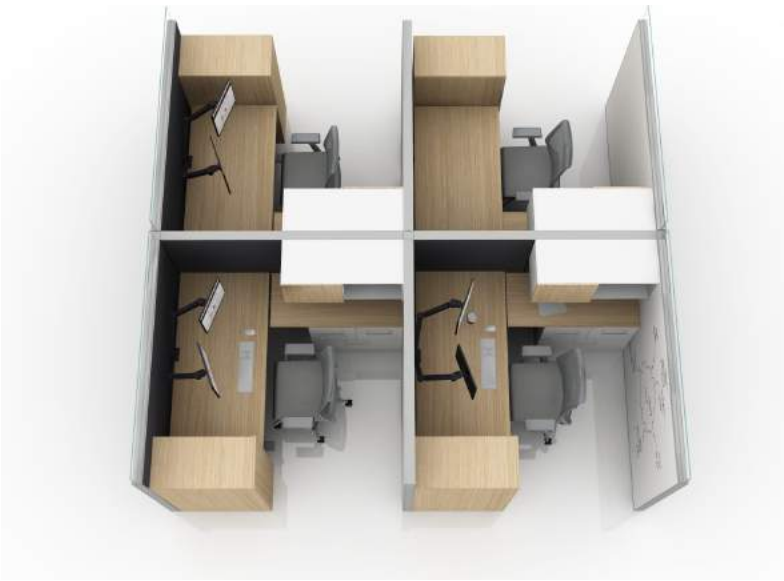

office

10x10 concepts



office

10x15 concepts



office

15x15 concepts



6 mock up

Mockup Lead Time Guide

Stated in business days | Transit times & pre-installs not included

Category	Product	Days	
Systems Product	Belong Plus Screens	15	
	Compose	5-8	
	Intuity	5-8	
	Pads/Frame: PREMISE	5-8	
	Panel Systems: PREMISE	5-8	
	Panel Systems: Unigroup, PLACES, Unigroup Too	5-8	
	Patterns	10-15	
	Patterns Cushion	5-8	
	Race- Call for quote	5-8	
	Reside	5-8	
	Worksurfaces	5-8	
	Worktools (Jump Stuff, Boogie Board)	5-8	
Accessories	Active Components	5-8	
	Belong	5-8	
	Belong Blotter	20	
	Ergotron	5-8	
	Overheads	5-8	
	Systems Lighting	5-8	
	Tackboards	5-8	
	Storage & Organization	950 Series Files	5-8
		A Series Storage	5-8
		All Steel Pedestal units	5-8
A,X,V, Storage Steel with Veneer Fronts		5-8	
Beside Storage		5-8	
Compose Storage		5-8	
Personal Storage Tower		5-8	
PLACES Storage		5-8	
V Series Storage		5-8	
X Series Storage		5-8	
X Series storage with Laminate Fronts		10	
Private Office		Compose/Masters Laminate Casegoods & Storage	9-10
	Masters	9-10	
	Masters Lamena	10-15	
	Suite	25	
	X Series Desks	9-10	

Category	Product	Days
Walls	Enclose/Enclose Frameless Glass- Call for quote	
	Trivati	
Technology & Shared Workspaces	450 Series	15
	Harbor Work Lounge	15
	Hoop Tables- Call for quote	
	Hop	5-8
	Immerse	25
	Jive, Jump & Swivel	10-15
	Openest	10-15
	Openest screens/ pillows	10-15
	Pip Personal Laptop	15
	Planes Height Adjustable	5-8
	Planes Collaborative	5-8
	Planes Conference/Training	5-8
	Wood Executive Tables	25
	Workware - Connect Interfaces/Processors	10
	Workware Easet	15
Workware - View Table/Wall mounts	10	
Workware - Wireless	10	
Seating	Improv Task & Side	4
	Fern	4
	Hello Lounge	
	Lively	4
	Look	4
	Poppy Guest	40
	Poppy Lounge	10
	Riverbend & Pebble Lounge	
	Soji	4
	Very	4
	Very with Tetra back	4
	Very Task	4
	Wood Seating	10
	X99 & Seminar	
	Zody	4

Category	Product	Days	
Haworth Collection	North America:		
	Seating:		
	Collaborate	15	
	Hi Pad (Side Chair)	15	
	Hi Pad (Stools)	15	
	Lotus	15	
	LTB	15	
	m_sit	15	
	Morrison Stool	15	
	q_bic	15	
	SE04	15	
	Tate Color (Laminate Seat)		
	Windowseat	15	
	Tables/Storage:		
	Bay	40	
	Collaborate (Laminate)	25	
	Collaborate (Veneer)	40	
	Encourage	40	
	LTB	30	
	NC-B Resonate	40	
	q_bic	30	
	SE04	30	
	Pablo Designs:		
	All Lightings (except LIM)	5-8	
	LIM	5-8	
	Rugs:		
	Gan	30	
	Europe: b_sit, Exchange, s_con	80	
	Cappellini: Basket	80	
	Poltrona Frau Group: Poltrona Frau, Cappellini, Cas	70	
	Cappellini: Luxor	80	
	HHE	Conover Casegoods	30
		Exam Stools & Tables	30
		Standard HHE	10-15
		Overbed Tables	30

General Notes

LEAD TIMES:	subject to change based on incoming order volumes and plant capabilities, calculated from the date of a clean order receipt to the day of product shipment from Haworth, products with hyperlink indicate special lead time details	MULTIPLE PRODUCTS:	order will be scheduled to longest lead time unless you move it onto its own delivery group
PREINSTALLS:	6 stations or less- add 3 days 7 stations or more- call 616-393-1178 for a time frame	NON-CATALOGS:	please contact your Haworth Customer Service Specialist before making commitments
TRANSIT TIMES:	<u>NOT</u> included in lead time, see the following for Transit Time by Zone: Holland Transit Map Bruce Transit Map	EXTENDED LEAD TIMES:	Specials, COM products, Haworth Alliance Plus fabrics, Clear on QC Walnut, Clear on Rift Cut White Oak, unavailable fabric
CLEAN ORDERS:	valid PO, valid financials, final signed off approval drawings, complete and final site dimensions and complete finish codes and descriptions	ACKNOWLEDGMENTS:	24-48 Hours for Normal orders 48 Hours for COM's and Walls 72 Hours for HHE and Haworth Collection 24-96 Hours for Buzzy Space

Please call a Mockup Specialist at 1-616-393-1178 for further details

WE LEAVE YOU WITH THIS THOUGHT: WE'RE NOT CALLED A
CORPORATE-OFFICE-INTERIORS-WORKSTATION-BUSINESS
FOR A REASON. IT'S ALL ABOUT THE EXPERIENCE, THE
CREATIVITY AND THE CULTURE. LET US HELP YOU
#LOVEWHEREYOUWORK

THANK YOU.

WEARECULTURA.COM

Submitted and authorized by Anne Bengel.